

**Engineering Dynamics**  
**Homework 7**

1.

The revolving door consists of four doors which are attached to an axle  $AB$ . Each door can be assumed to be a 50-lb thin plate. Friction at the axle contributes a moment of 2.1 lb ft which resists the rotation of the doors. If a man passes through one door by always pushing with a force  $P=13$  lb perpendicular to the plane of the door as shown, determine the door's angular velocity after it has rotated  $90^\circ$ . The doors are originally at rest.

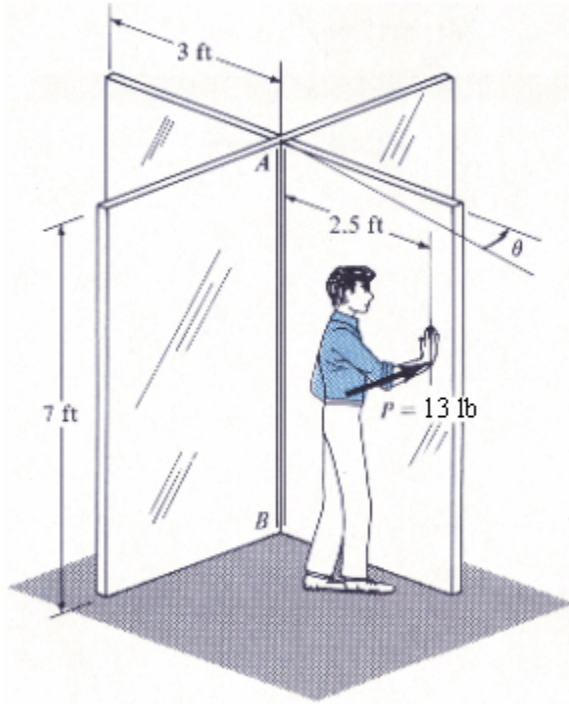

$\omega =$  \_\_\_\_\_ rad/s

2.

The 80-kg wheel has a radius of gyration  $k_O = 125$  mm and is rotating at 25 rad/s when the vertical force  $P = 210$  N is applied to the brake handle. If the coefficient of friction between the brake at  $B$  and the wheel is  $\mu = 0.36$ , determine the number of revolutions  $n$  the wheel makes before it stops. What are the horizontal and vertical components of reaction at  $A$  while the wheel is stopping.

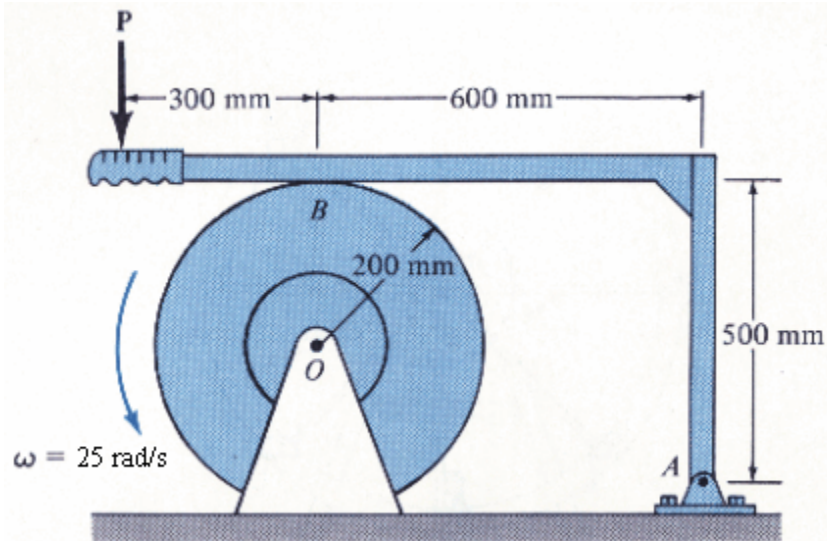

$n =$  \_\_\_\_\_ revolutions

$A_x =$  \_\_\_\_\_ N

$A_y =$  \_\_\_\_\_ N

3.

The linkage consists of two 7-lb rods  $AB$  and  $CD$  and a 12-lb rod  $AD$ . When  $\theta=0$ , rod  $AB$  is rotating with an angular velocity  $\omega_{AB}=2$  rad/s. If at this instant rod  $CD$  is subjected to a couple moment  $M=15$  lb ft and rod  $AD$  is subjected to a horizontal force  $P=21$  lb as shown, determine  $\omega_{AB}$  at the instant  $\theta=90^\circ$ .

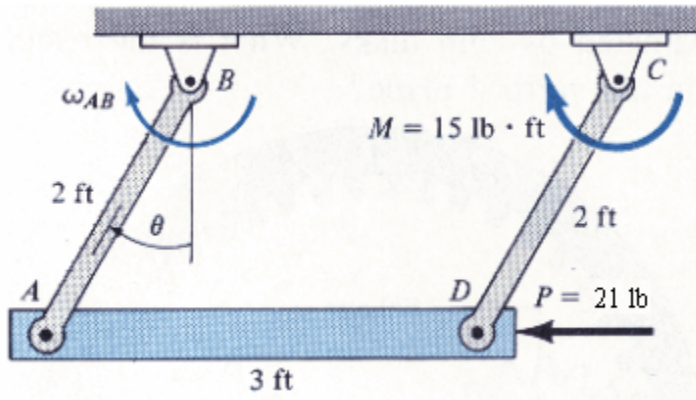

$\omega_{AB} =$  \_\_\_\_\_ rad/s

4.

A man having a weight of 165 lb crouches down on the end of a diving board as shown. In this position the radius of gyration about his center of gravity is  $k_G = 1.3$  ft. While holding this position at  $\theta = 0^\circ$ , he rotates about his toes at  $A$  until he loses contact with the board when  $\theta = 90^\circ$ . If he remains rigid, determine approximately how many revolutions he then makes before striking the water after falling 40 ft.

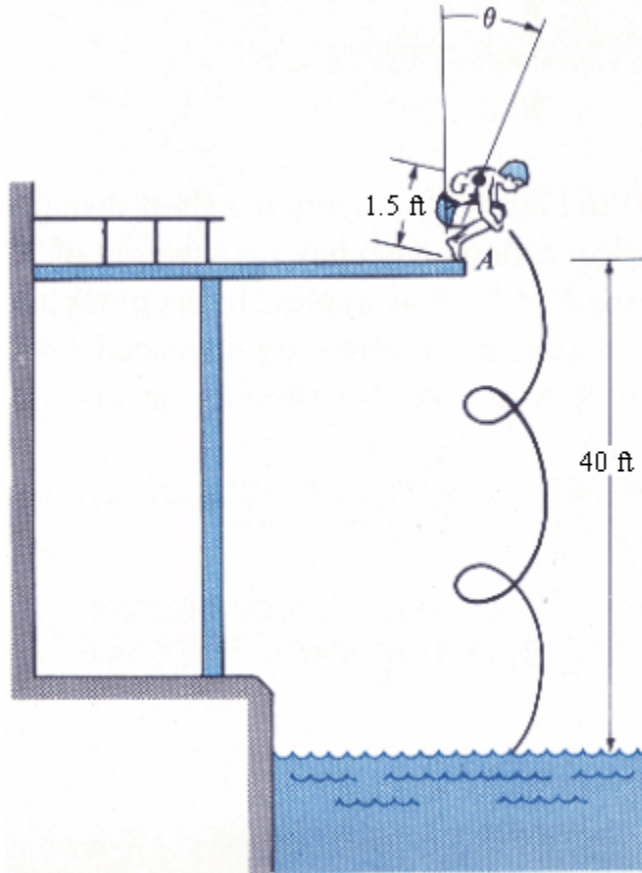

$n =$  \_\_\_\_\_ revolutions

5.

A vertical force  $P = 1.6 \text{ kN}$  is used to lift the 18-kg wheel and the 50-kg crate  $B$ .

Assuming that the rope does not slip over the wheel, determine the speed of  $B$  after the center  $O$  of the wheel rises 2 m starting from rest. The radius of gyration of the wheel is  $k_O = 125 \text{ mm}$ . Neglect the mass of the rope.

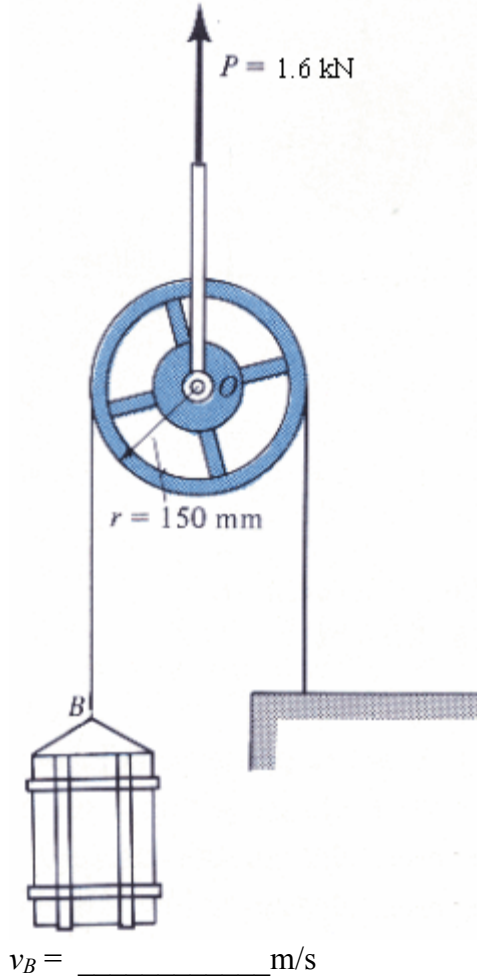

6.

The spool has a mass of 180 kg and a radius of gyration  $k_O = 525$  mm. If a man having a mass of 65 kg grabs the end of the cable and steps off the ledge from an at-rest position, determine his velocity when he strikes the ground. Neglect the mass of the cable.

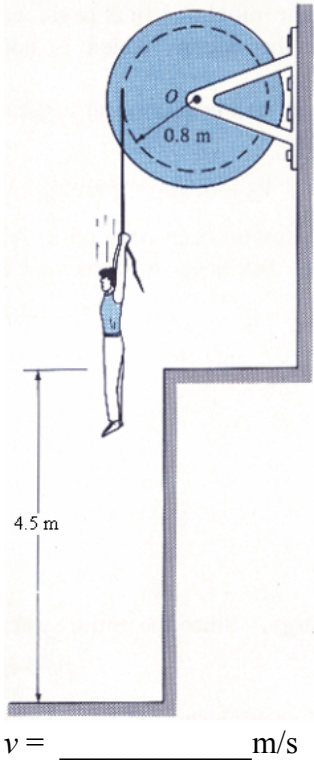

7.

A girl having a weight of 100 lb is sitting on a swing such that when she is at  $A$ ,  $\theta=30^\circ$ , her velocity is equal to zero and her center of gravity is at  $G$ . If she keeps this same fixed (rigid) position as she swings forward, determine the angular velocity of the swing when she reaches the lowest point at  $B$  ( $\theta=0^\circ$ ). Her radius of gyration about an axis passing through  $G$  is 1.7 ft.

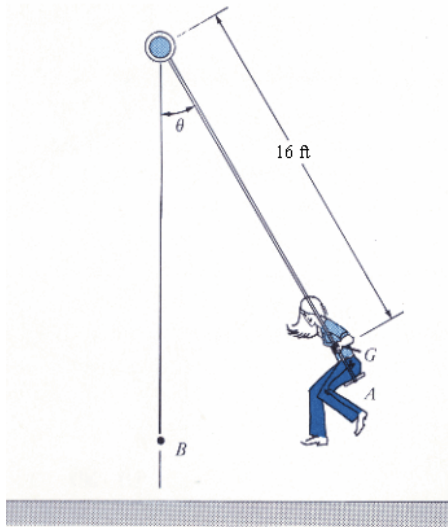

$\omega =$  \_\_\_\_\_ rad/s

8.

The window  $AB$ , shown in side view, has a weight of 8 lb, a center of gravity at  $G$ , and a radius of gyration  $k_A = 1.5$  ft about its hinged axis at  $A$ . If the spring is unstretched when  $\theta \approx 0^\circ$  and the window is released from rest from this position, determine the speed with which the end  $B$  strikes the wall  $D$ ,  $\theta = 90^\circ$ . Neglect friction at the hinge  $A$  and at pulley  $C$ .

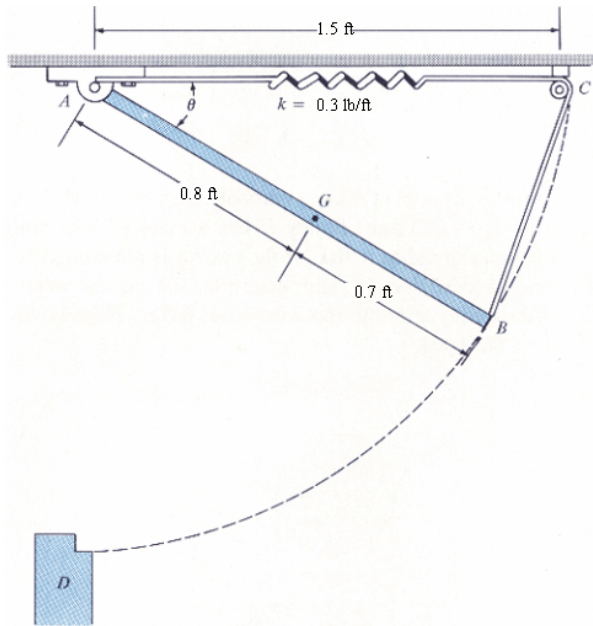

$v_B =$  \_\_\_\_\_ ft/s

9.

The slender rod has a mass of 11 kg and is released from rest when  $\theta=0^\circ$ . Determine its angular velocity at the instant  $\theta=30^\circ$ . The attached block at  $D$  has a mass of 4 kg. The mass of the cable and pulley at  $C$  can be neglected.

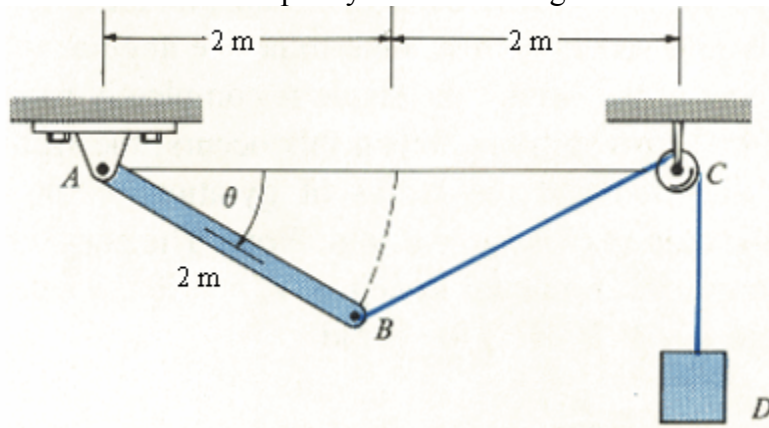

$\omega =$  \_\_\_\_\_ rad/s